

## Hollow pin conveyor chains (ZC series)

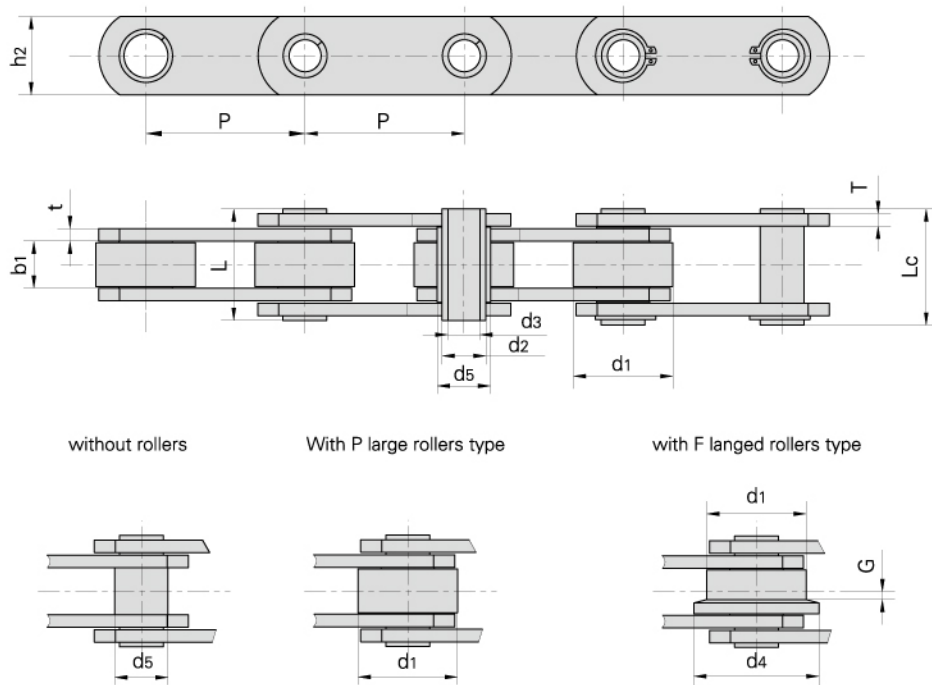

Donghua Chain No.	Pitch							Roller dimension			Bush diameter	Plate depth
	P							d1 max	d4 max	G	d5 max	h2 max
	mm							mm	mm	mm	mm	mm
ZC21	38.1	50.8	63.5	76.2	-	-	-	25.40	-	-	11.0	18.0
ZC40	50.8	63.5	76.2	88.9	101.6	127.0	152.4	31.75	40.0	2.5	17.0	25.0
ZC60	76.2	88.9	101.6	127.0	152.4	177.8	203.2	47.50	60.0	3.5	23.0	40.0
ZC150	101.6	127.0	152.4	177.8	203.2	228.6	254.0	66.70	82.0	4.0	33.0	50.0
ZC300	152.4	177.8	203.2	254.0	304.8	-	-	88.90	114.0	8.5	38.0	60.0

Donghua Chain No.	Width between inner plates	Pin diameter			Pin length		Plate thickness	Breaking load	
	b1 min mm	d2 max mm	d3 min mm	L max mm	Lc max mm	t/T max mm	Q min kN/LB	*Q min kN/LB	
ZC21	12.7	9.0	6.5	26.0	27.5	2.5	21.0/4772	27.1/6159	
ZC40	15.0	14.0	10.2	36.4	37.7	4.0	40.0/9091	50.0/11362	
ZC60	19.0	19.0	13.2	45.0	46.5	5.0/4.0	60.0/13636	120.0/27270	
ZC150	26.0	26.9	20.2	58.0	60.5	7.0/5.0	150.0/34087	190.0/43177	
ZC300	38.0	32.0	22.5	83.0	85.0	10.0/8.0	300.0/68175	380.0/86362	

\*Q Higher breaking load with hardened plates