

Conveyor chains (ZE series)

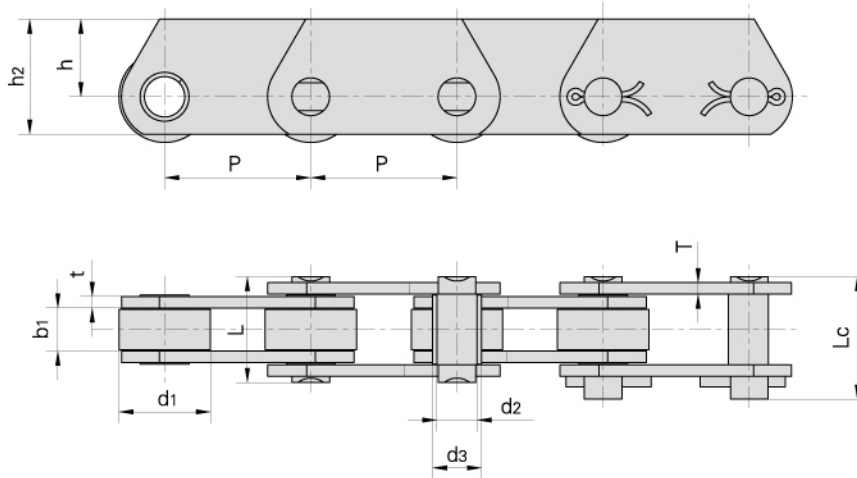

Donghua Chain No.	Pitch							Roller diameter	Pin diameter	Bush diameter
	P							d1 max	d2 max	d3 max
	mm							mm	mm	mm
ZE40	50.8	63.5	76.2	88.9	101.6	127.0	152.4	31.75	14.0	17.0
ZE100	76.2	88.9	101.6	127.0	152.4	177.8	203.2	47.50	19.0	23.0
ZE160	101.6	127.0	152.4	177.8	203.2	228.6	254.0	66.70	26.9	33.0
ZE300	152.4	177.8	203.2	254.0	304.8	-	-	88.90	32.0	38.0

Donghua Chain No.	Width between inner plates	Pin length		Plate depth		Plate thickness	Breaking load	
	b1 min	L max	Lc max	h2 max	h max	t/T max	Q min	*Q min
	mm	mm	mm	mm	mm	mm	kN/LB	kN/LB
ZE40	15.0	37.0	40.5	40.0	27.0	4.0	40.0/9091	60.0/13636
ZE100	19.0	45.0	50.5	50.0	30.0	5.0/4.0	100.0/22725	160.0/36360
ZE160	26.0	58.0	63.5	70.0	45.0	7.0/5.0	160.0/36360	200.0/45454
ZE300	38.0	84.0	94.0	90.0	60.0	10.0/8.0	300.0/68175	380.0/86362

*Q Higher breaking load with hardened plates