

## SP series high strength heavy duty short pitch roller chains

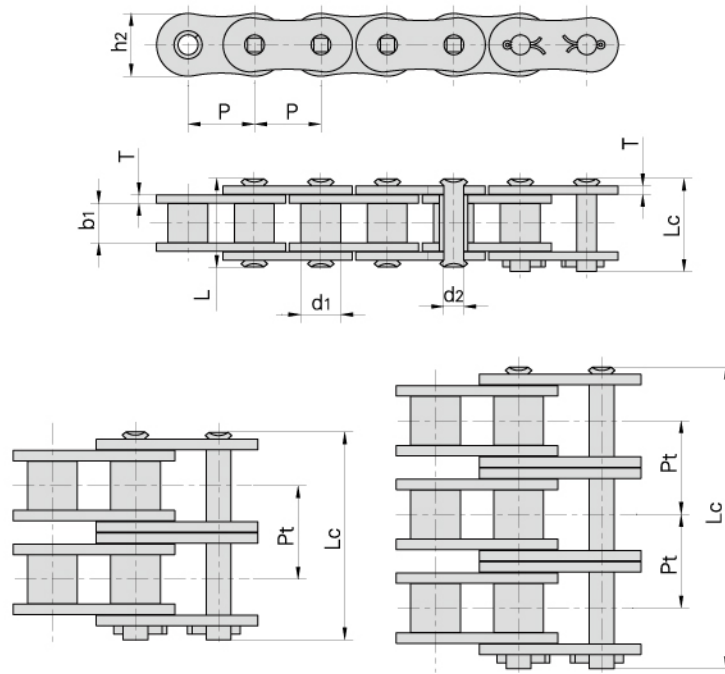

Donghua Chain No.	Pitch	Roller diameter	Width between inner plates	Pin diameter	Pin length		Inner plate depth	Plate thickness	Transverse pitch	Ultimate tensile strength	Average tensile strength	Weight per meter
	P	d1 max	b1 min	d2 max	L max	Lc max	h2 max	T	Pt	Q min	Q0	q
	mm	mm	mm	mm	mm	mm	mm	mm	mm	kN/LB	kN	kg/m
80HSP-1	25.40	15.88	15.75	7.94	36.2	38.9	24.1	4.0	-	89.2/20066	98.1	3.36
100HSP-1	31.75	19.05	18.95	9.54	43.6	46.9	30.1	4.8	-	131.8/29649	145.0	4.90
120HSP-1	38.10	22.23	25.22	11.11	53.5	57.5	36.2	5.6	-	176.0/39592	196.0	7.12
140HSP-1	44.45	25.40	25.22	12.71	57.6	62.2	42.2	6.4	-	231.9/52149	255.0	8.88
160HSP-1	50.80	28.58	31.55	14.29	68.2	73.0	48.2	7.2	-	294.5/66260	324.0	11.72
200HSP-1	63.50	39.68	37.85	19.85	86.6	93.5	60.3	9.5	-	543.6/122295	598.0	19.80
80HSP-2	25.40	15.88	15.75	7.94	68.8	72.0	24.1	4.0	32.59	178.4/40132	196.2	6.65
100HSP-2	31.75	19.05	18.95	9.54	82.7	86.0	30.1	4.8	39.09	263.6/59299	290.0	9.71
120HSP-2	38.10	22.23	25.22	11.11	102.4	106.4	36.2	5.6	48.87	356.4/80175	392.0	14.12
140HSP-2	44.45	25.40	25.22	12.71	109.8	114.4	42.2	6.4	52.20	463.6/104300	510.0	17.38
160HSP-2	50.80	28.58	31.55	14.29	130.1	134.9	48.2	7.2	61.90	588.0/132275	647.0	23.00
200HSP-2	63.50	39.68	37.85	19.85	164.9	171.8	60.3	9.5	78.31	1091.0/245429	1200.0	38.50
80HSP-3	25.40	15.88	15.75	7.94	101.4	104.6	24.1	4.0	32.59	267.6/60200	294.3	9.95
100HSP-3	31.75	19.05	18.95	9.54	121.8	125.1	30.1	4.8	39.09	395.4/88948	435.0	14.53
120HSP-3	38.10	22.23	25.22	11.11	151.2	155.2	36.2	5.6	48.87	534.5/120250	588.0	21.12
140HSP-3	44.45	25.40	25.22	12.71	162.0	166.6	42.2	6.4	52.20	695.5/156448	765.0	25.88
160HSP-3	50.80	28.58	31.55	14.29	192.0	196.8	48.2	7.2	61.90	882.7/198576	971.0	34.22
200HSP-3	63.50	39.68	37.85	19.85	243.2	250.1	60.3	9.5	78.31	1627.3/366073	1790.0	57.29